

TYPICAL MAST BASE FOOTING DETAIL

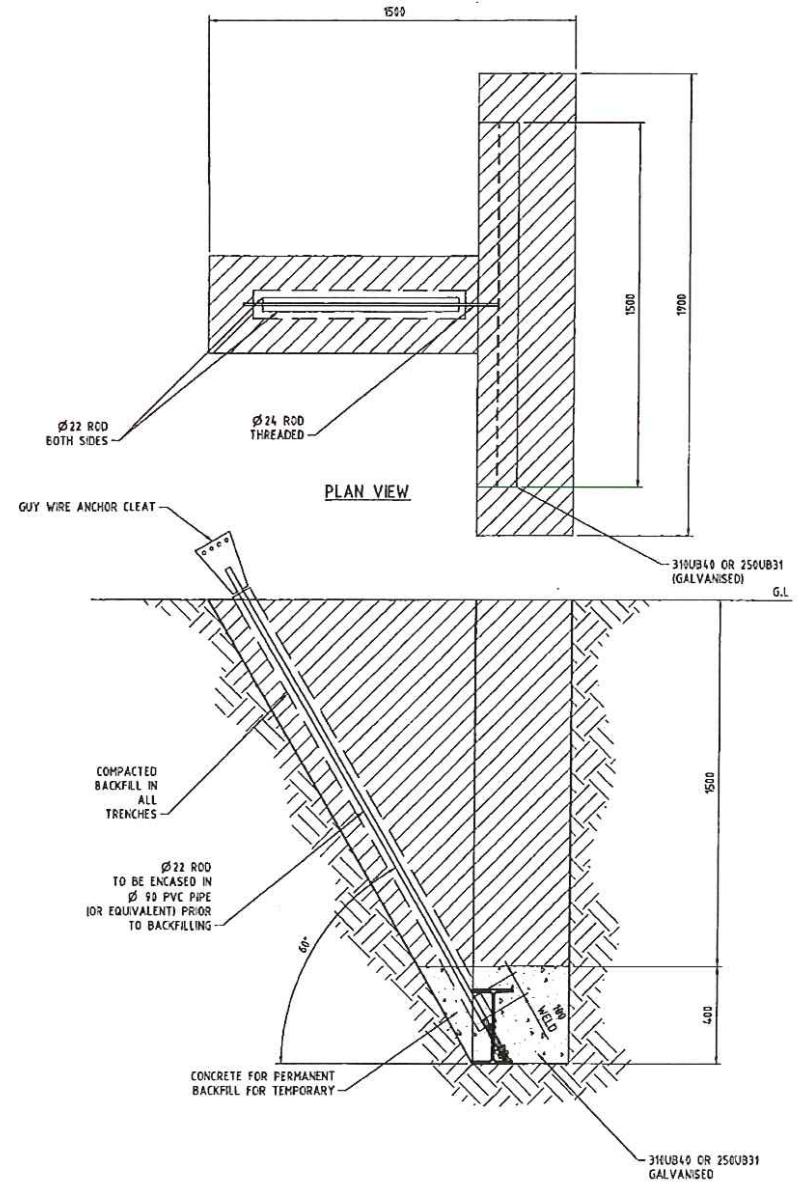

TYPICAL GUY ANCHOR FOOTING DETAIL

- NOTES:**
1. THIS DRAWING SHALL BE READ IN CONJUNCTION WITH THE GENERAL NOTES
 2. THESE NOTES SHALL BE READ WITH SPECIFICATIONS AND ALL OTHER RELEVANT DRAWINGS AND OR SKETCHES. ANY DISCREPANCIES SHALL BE REFERRED TO THE ENGINEER PRIOR TO THE COMMENCEMENT OF ANY WORK.
 3. ALL DIMENSIONS SHALL BE VERIFIED ON SITE PRIOR TO THE START OF ANY WORK. ENGINEERS DRAWINGS AND/OR SKETCHES SHALL NOT BE SCALED. REFER TO ARCHITECTS DRAWINGS FOR DIMENSIONS.
 4. MATERIAL AND WORKMANSHIP SHALL CONFORM TO RELEVANT CURRENT S.A. CODES AND THE PROJECT SPECIFICATIONS.
 5. ALL EXPOSED STEEL TO BE HOT DIP GALVANISED.

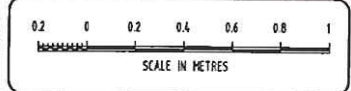

REVISIONS				
NO.	DATE	BY	CHKD.	DESCRIPTION
A	18/07/20			ISSUED FOR REVIEW

CLIENT	RIGRIGHT	
PROJECT	80 METER MAST	
DRAWING TITLE	FOOTINGS DETAIL SHEET	
DRAWING No.	7534G-DR-503	REV. A



AGB Group
AGN
COB 877 401

STRUCTURAL	HYAC
CIVIL	ENVIRONMENT
MECHANICAL	ENERGY RATING
ELECTRICAL	RISK MANAGEMENT
INDUSTRIAL	OH & S
HYDRAULIC	RECRUITMENT
FIRE	TRAINING

31 BARWON TERRACE, SOUTH GEELONG, P.O. BOX 1284, GEELONG, 3218
 PHONE: (03) 5221 2611
 FAX: (03) 5221 8675
 WEB: www.agbgroup.com.au
 EMAIL: geelong@agbgroup.com.au

THIS DRAWING IS BASED ON INFORMATION PROVIDED BY OTHERS, AND WHILE AGB GROUP ENDEAVOURS TO ENSURE THE CORRECTNESS OF THIS INFORMATION, NO LIABILITY WILL BE ACCEPTED FOR ANY ERRORS OR OMISSIONS CAUSED BY THE USE OF THIS INFORMATION.

- NOTES:**
1. THIS DRAWING SHALL BE READ IN CONJUNCTION WITH THE GENERAL NOTES.
 2. THESE NOTES SHALL BE READ WITH SPECIFICATIONS AND ALL OTHER RELEVANT DRAWINGS AND OR SKETCHES. ANY DISCREPANCIES SHALL BE REFERRED TO THE ENGINEER PRIOR TO THE COMMENCEMENT OF ANY WORK.
 3. ALL DIMENSIONS SHALL BE VERIFIED ON SITE PRIOR TO THE START OF ANY WORK. ENGINEERS DRAWINGS AND/OR SKETCHES SHALL NOT BE SCALED. REFER TO ARCHITECTS DRAWINGS FOR DIMENSIONS.
 4. MATERIAL AND WORKMANSHIP SHALL CONFORM TO RELEVANT CURRENT S.A. CODES AND THE PROJECT SPECIFICATIONS.
 5. ALL EXPOSED STEEL TO BE HOT DIP GALVANISED.

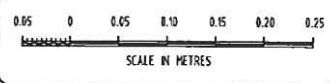
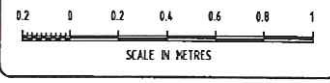

REVISIONS

No.	Date	By	Rev.	Description
A	18/7/11	ME	10	ISSUED FOR REVIEW
B	19/7/11	ME	11	RE-ISSUED FOR REVIEW

CLIENT RIGRIGHT

PROJECT 80 METER MAST

DRAWING TITLE MAST SECTION DETAIL SHEET

DRAWING No. 7534G-DR-S05 REV. B



AGB Group
ACM
008 872 481

STRUCTURAL CIVIL MECHANICAL ELECTRICAL INDUSTRIAL HYDRAULIC FIRE	HVAC ENVIRONMENT ENERGY RATING RISK MANAGEMENT OH & S RECRUITMENT TRAINING
--	--

31 BARKHUN TERRACE,
SOUTH GEELONG
P.O. BOX 1084,
GEELONG, 3220
PHONE: (03) 5221 2611
FAX: (03) 5221 8675
WEB: www.agbgroup.com.au
EMAIL: geelong@agbgroup.com.au

THIS DRAWING IS BASED ON INFORMATION PROVIDED BY OTHERS, AND WHILST AGB GROUP ENDEAVOURS TO ENSURE THE CORRECTNESS OF THIS INFORMATION, NO LIABILITY WILL BE ACCEPTED FOR ANY ERRORS OR OMISSIONS CAUSED BY THE USE OF THIS INFORMATION.

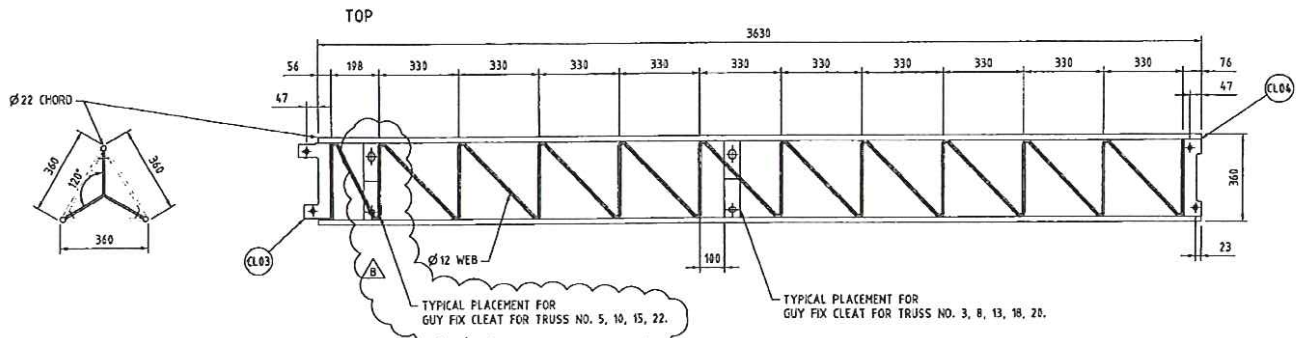

3630 TYPICAL MAST SECTION

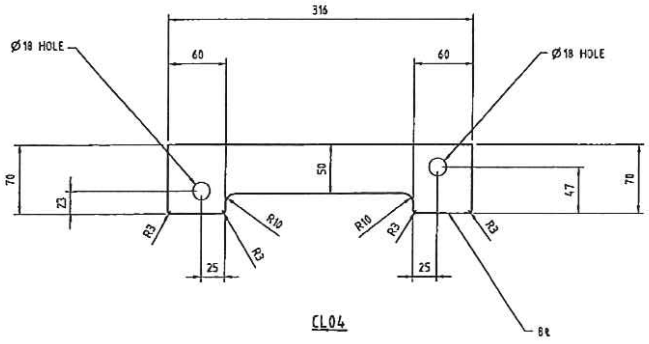
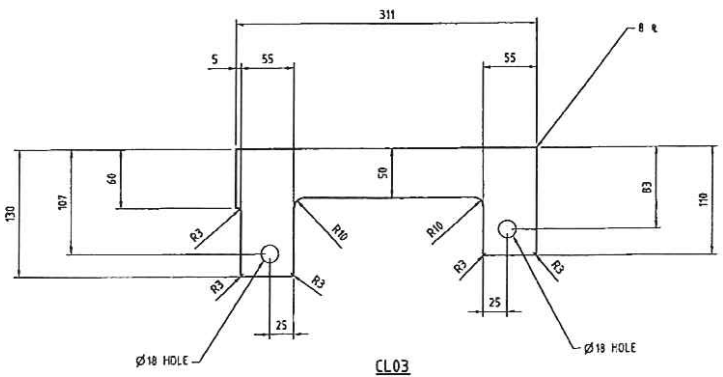
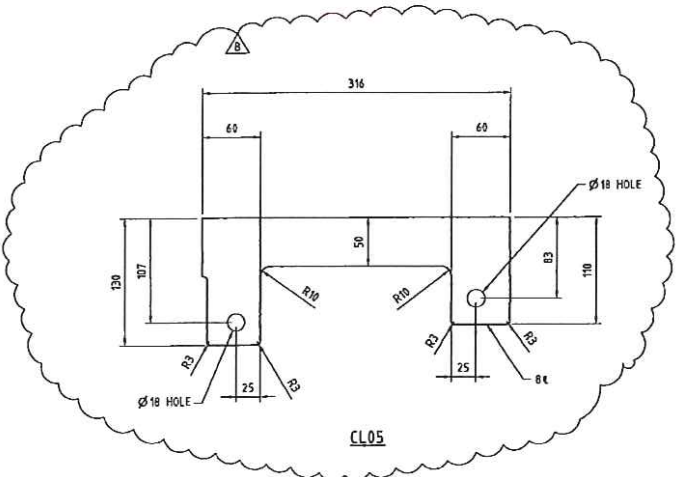

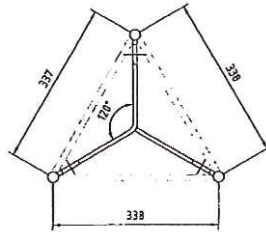

END VIEW

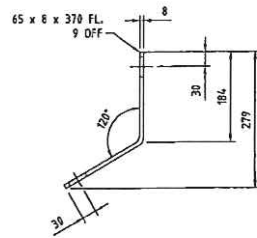

PLAN VIEW

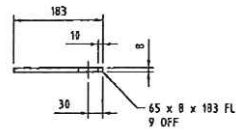

PLAN VIEW

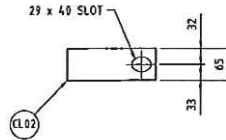
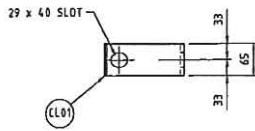

GUY FIX CLEAT FOR 80 METER MAST

NOTES:

1. THIS DRAWING SHALL BE READ IN CONJUNCTION WITH THE GENERAL NOTES
2. THESE NOTES SHALL BE READ WITH SPECIFICATIONS AND ALL OTHER RELEVANT DRAWINGS AND OR SKETCHES. ANY DISCREPANCIES SHALL BE REFERRED TO THE ENGINEER PRIOR TO THE COMMENCEMENT OF ANY WORK.
3. ALL DIMENSIONS SHALL BE VERIFIED ON SITE PRIOR TO THE START OF ANY WORK. ENGINEERS DRAWINGS AND/OR SKETCHES SHALL NOT BE SCALED. REFER TO ARCHITECTS DRAWINGS FOR DIMENSIONS.
4. MATERIAL AND WORKMANSHIP SHALL CONFORM TO RELEVANT CURRENT S.A. CODES AND THE PROJECT SPECIFICATIONS.
5. ALL EXPOSED STEEL TO BE HOT DIP GALVANISED.

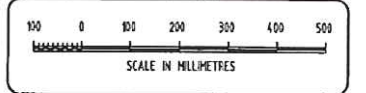

REVISIONS				
NO.	DATE	BY	CHKD.	DESCRIPTION
A	18/37			ISSUED FOR REVIEW

CLIENT	RIGRIGHT
PROJECT	80 METER MAST
DRAWING TITLE	GUY FIX CLEAT DETAIL SHEET
DRAWING No.	7534G-DR-S07
REV.	A

STRUCTURAL
CIVIL
MECHANICAL
ELECTRICAL
INDUSTRIAL
HYDRAULIC
FIRE

HVAC
ENVIRONMENT
ENERGY RATING
RISK MANAGEMENT
OH & S
RECRUITMENT
TRAINING

31 BARROW TERRACE, SOUTH CEELING, P.O. BOX 1884, CEELING, 3229

PHONE: (03) 5221 2611
FAX: (03) 5221 8675
WEB: www.agbgroup.com.au
EMAIL: geelong@agbgroup.com.au

THIS DRAWING IS BASED ON INFORMATION PROVIDED BY OTHERS, AND WHILE AGB GROUP DISAVOWS TO ENSURE THE CORRECTNESS OF THIS INFORMATION, NO LIABILITY WILL BE ACCEPTED FOR ANY ERRORS OR OMISSIONS CAUSED BY THE USE OF THIS INFORMATION.